



ATTENTION

Quick and Easy Installation Guide.

For **KingspanWater**
Envireau Product.

007018 ISSUE 03: MARCH 2011 CC916

DOMESTIC GRAVITY SYSTEM

KingspanWater

For After Sales Customer Care queries please contact:

NI: 028 3025 4077 | IRL: 048 3025 4077

GB WARRANTY: 0844 225 2785

We recommend annual servicing of this product.

For more information please contact the Kingspan Environmental Service team:

GB: 01264 325 2285 | NI: 028 3025 4077 | IRL: 048 3025 4077

Gravity System Overview

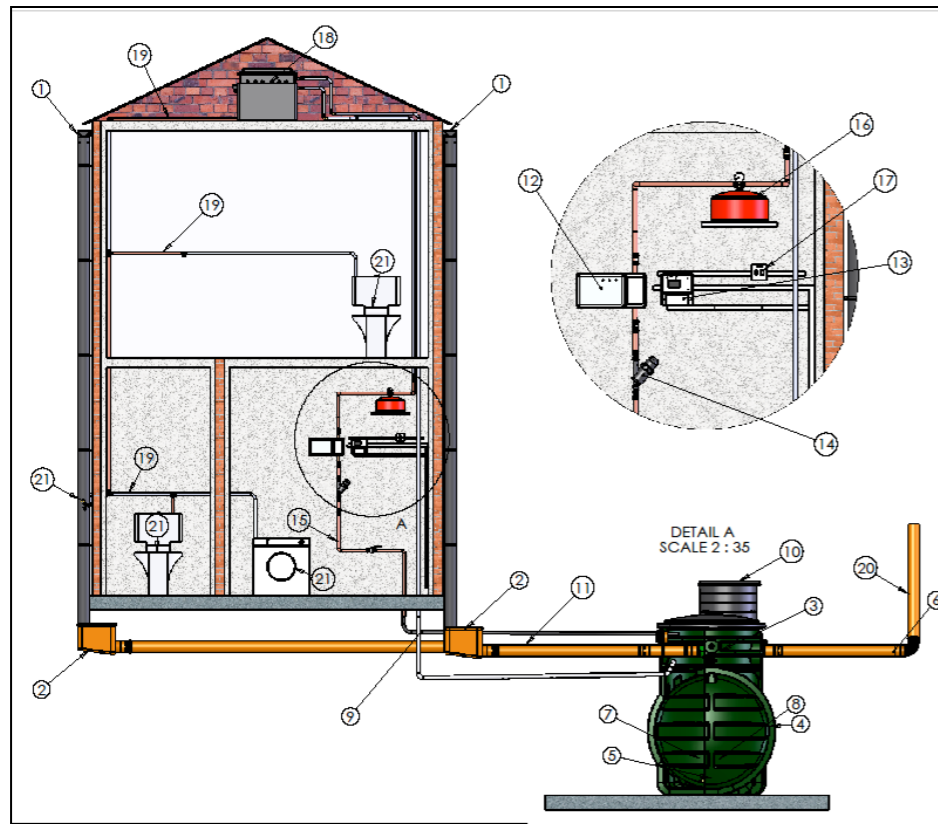

Key:

1. Rainwater drain from property to storage tank.
2. Integral Leaf filter
3. Storage tank rain water inlet.
4. Storage tank (C/W Supply pump & Level sensor).
5. Tank overflow.
6. Inline 125 micron filter.
7. Control panel.
8. Pressure Vessel (Minimum 5 Litres).
9. Display/Setup Panel.
10. Mains water top up.
11. Header Tank (Not Supplied As Standard)

Have You Considered?

Pressure Vessel?

These are a system requirement and it is essential these are sized to suit your specific application.



Header Tank?

As you are installing a Gravity system a Header Tank is an essential part of the system. Please ensure this is sized to suit your particular application.



Internal/External Pipe and Fittings?

Your delivery will NOT include any internal/external pipe and fittings that you will require to complete your installation. Please ensure all fittings are securely fitted to avoid any system issues.

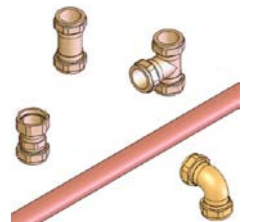

Tank & Control Kit Installation.

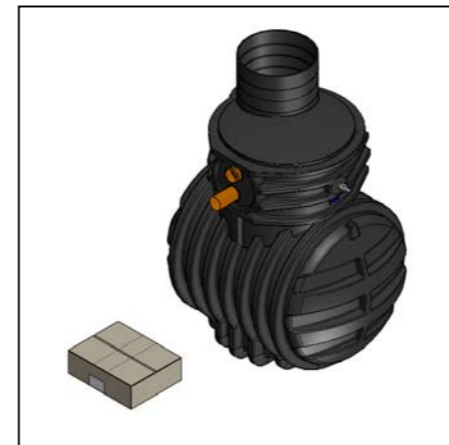

Step 1 (Delivery):

Firstly you must ensure you have received all components ordered. Please check your order against the delivery ticket which will list all delivered parts. Standard delivery will consist of a storage tank (size and style will vary from picture) and a boxed kit of parts. If there are any shortages or damaged components please contact us immediately.

Step 2 (Excavation):

Excavate a sufficient hole to suit storage tank (check sales drawings for dimensions). Ensure depth allows for a suitable concrete base (min 300mm), and there is sufficient room around tank for relevant backfill. If excavation walls are unstable use trench sheeting to shore up walls. A dewatering pump maybe required to remove excess water.





Step 3 (Positioning):

Lay the concrete base (min 300mm). Once cement is cured, lower the tank into the excavation, ensure you use correct lifting equipment, lift with webbing slings do not use chains. Ensure tank is level and all connections line up with site pipe work (if you are using an external filter you need to allow for these levels). Ensure access shafts are covered to avoid any debris falling into the tank during backfilling.

Step 4 (Backfill):

If necessary locate a dewatering pump in the base of the excavation to remove excess water (wet sites only). Fill the tank with water to approximately 300mm from base DO NOT OVERFILL. Backfill around tank with suitably selected material (concrete or pea shingle) DRY SITES ONLY, until level with the water line inside the tank. Fill tank and backfill in 300mm stages until you reach pipe connection levels.
NB: Picture shows concrete backfill

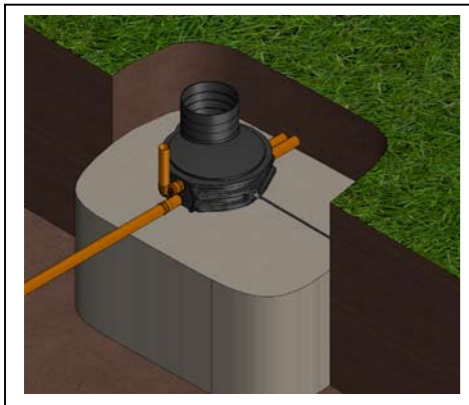

Step 5 (Pipe Connections):

Connect rainwater drain to the inlet pipe on the storage tank
Connect the overflow pipes to the relevant soak away/water course/sewer etc.
Connect Ø25mm rainwater supply pipe to fitting in neck & run back to property.
Connect mains top up supply pipe, this is clearly labelled on tank, and run pipe back to property.
Run suitably sized electrical ducting, with draw wire, from neck to property.

Step 6 (Pump/Level Sensor Fitting):

The level sensor is pre-fitted in the neck of the tank at ground level.
Assemble the pump fittings, uncoil the hose in the tank and attach to the pump. Attach the suction filter to the pump. Ensure the rope is securely attached to pump.
Carefully lower the pump assembly into the tank shaft and locate upright on the base of the tank.
Run pump & level sensor cable back to the property with draw wire.
Finish by tying the pump rope to the U bolt in neck.

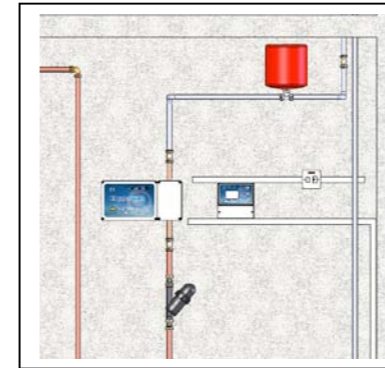

Step 7 (Component Connections):

Connect the rain water MDPE pipe to suitable internal pipe work via a stop cock then to the components in the following order:

1. Inline leaf filter.
2. Control panel plumbing box (fixed to wall).
3. Suitably sized pressure vessel (supplied by others).
4. Fix set up/display panel to the wall.

Step 8 (Header Tank Connection):

Run the pipe work from the pressure vessel to the header tank normally located in the roof space (NB please ensure your header tank is sized to suit your particular application).
Run the mains pipe to the header tank and connect to the top pipe connection.
Run pipe work from header tank and connect to relevant appliances in property.

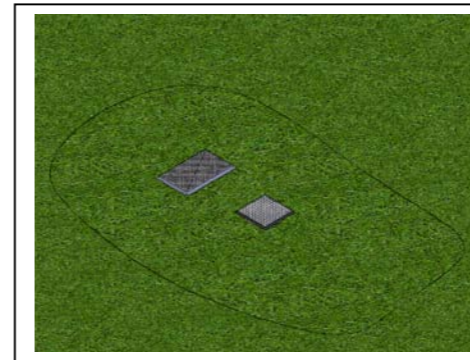

Step 9 (Finishing):

Continue to backfill the tank up to ground level. When ground level is achieved trim the Ø600mm extension necks to suit.
Fit man hole cover.
NB: Pedestrian duty man hole cover supplied as standard, this is not suitable for traffic loading.

Your Tank Installation Is Complete.

Before continuing to Control & Display panel Connection check:

1. System layout and install is as per the System Schematic Drawing supplied.
2. Any debris, soil, dust etc that has accumulated during install is removed from the tank (to avoid blocking filter and supplying dirty water to system).
3. Pump is standing upright and filter is also vertical.
4. Pump, hose and fitting joints are sealed (if not suitably sealed it will cause system issues).
5. Leaf Filter mesh is present in the housing.

Control Panel & Display Panel Connection Detail.

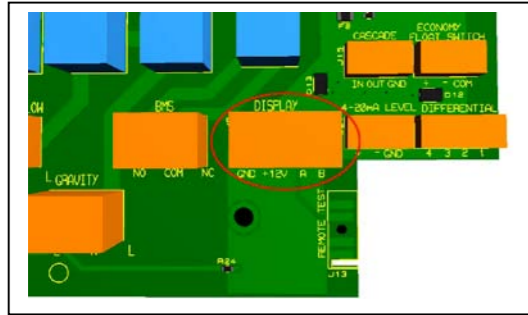

Step 1:
 The display panel should already be mounted in suitable location inside the property.
 Wire the display unit back to the control unit (up to 300m). The cable should be four cores at 1 amp per core rating (7/0.2 mm each core). The cable should be connected between the “REMOTE” terminal block on the DISPLAY unit to the remove terminal block on the CONTROL unit.

Step 2:
 Locate the solenoid valve and install a local Switched Fused Spur (3 amp). Wire in the Solenoid Valve connector. Remove the screw on the back of the connector to release, then cable in to the spur using suitable 3 core cable. Feed the spur to the terminals in the controller marked DIRECT. Use the earth connection provided.

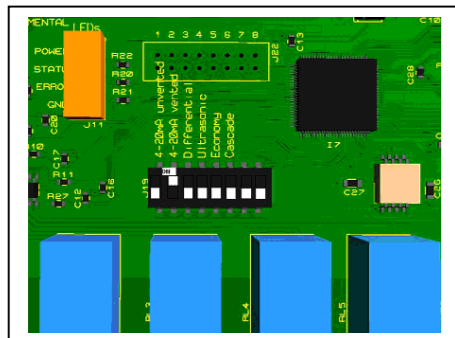
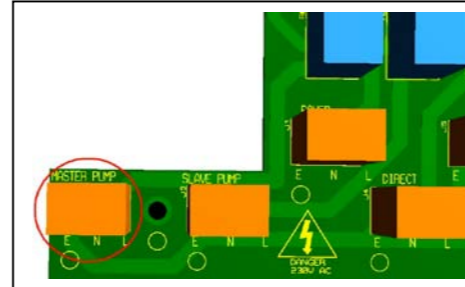

Step 3:
 There are several sensors you can connect to the rainwater panel. Check the dip switches settings located in the middle of the printed circuit board to see what sensor is used in your system (standard is 4-20mA vented).

Step 4:
 The sensor cable 2 cores should be connected in to the sensor terminal block (4-20Ma Level). The wires should be connected to the “+” and “-” pins, . If there is a cable screen it should be connected to the “GND” pin.

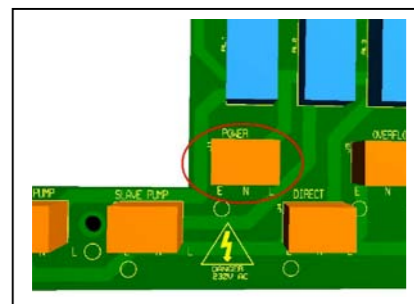
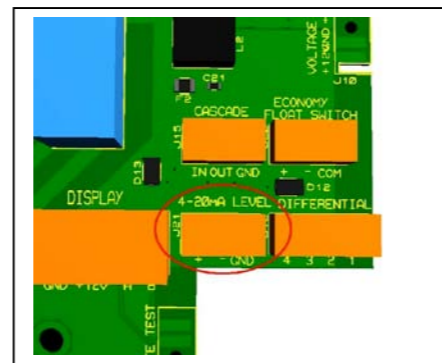

Step 5:
 The electrical supply should come from the Distribution Board fused or with MCB Type C rated 16 amps, with a separate Residual Current Detector (RCD) to an isolate switch local to the control unit, or from a 16 amp switched fused spur with integral RCD. The mains supply terminal block is marked “POWER” connect accordingly to L brown core, N blue core and E green/yellow core.

Your Control & Display Panels Are Now Connected

Set Up & Commissioning.



Step 1:
 Apply power to the system and observe the display unit. The system identifies that this is the first install and enters the setup wizard.

Step 2:
 The wizard prompts the user to “Drop the sensor into the tank”, which should already have been done.

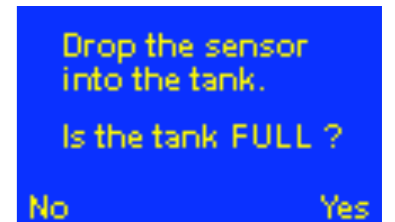

Step 3:
 The system now asks is the tank full. If the tank is full enter Yes using the “UP”, “DOWN” and “ENTER/MENU” keys. This automatically saves the height of water in the tank. If the tank is not full enter No. In this case manually enter the height of the tank in centimetres. Press ENTER to continue (tank heights can be obtained from tank manufacturer documentation)

Step 4:
 The controller now enters learning mode. The system will learn the maximum system operating pressure. The display will show an hour glass timer prompting the installer to wait until the system has fully pressurised. This will take a minimum of 4 minutes and, depending on the type of system, may take considerably longer. When max pressure has been learned the hour glass will disappear and the main screen will revert to normal mode.

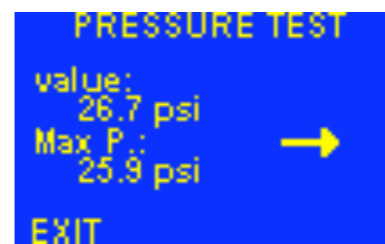
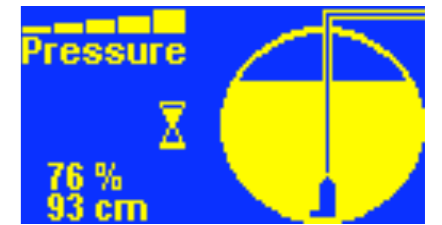

Step 5:
 To check that the system is pressurised go to “MAIN MENU”, go to “SETUP”, select “PRESSURE TEST” The pressure is indicated both by a readout expressing the system in PSI as well an arrow indicating the inclination of the pressure at that given moment. Ideally the system will show a steady pressure indicating that system has no leaks. If the system pressure is falling then there is an output open or there is a pressure leak.

You have now completed set-up and commissioning. Test all appliances and check to ensure that the STATUS indicator light (ORANGE), which may have illuminated during set-up, has now extinguished. If the STATUS indicator light fails to extinguish within five minutes, switch off the system and go to the “Troubleshooting” section in Full manual.

Service Tel: +44 (0) 845 355 0555
 Service Tel: +44 (0) 28 302 54077
 Service Fax: +44 (0) 28 302 60046

www.kingspanenv.com

